



**WATER SOFTENER
SEMI AUTOMATIC**

**INSTALLATION & OPERATING
INSTRUCTIONS**

Model : SAS0922
Serial No :

Manufacturer and Supplier of



FILTRATION & WATER TREATMENT PRODUCTS
for commercial, industrial and residential application



Telephone: (07) 3219 2233
Email: sales@ibcwater.com.au

Facsimile: (07) 3219 2266
Website: www.ibcwater.com.au

HARDNESS TEST

1. Water to be tested should be taken from a tap after the water softener
2. Measure 10ml of water into plastic bottle supplied (approximately 1/3 full)
3. Add one Yes/No tablet to sample water, replace cap and shake until tablet has completely dissolved.
(NOTE: do not handle Yes/No tablet with fingers)
4. The final colour to be obtained for soft water is green. (Note: The shade of green may vary.) If the colour turns red, the water is above 20 mg/l hardness, therefore another regeneration is recommended.
5. Rinse plastic bottle after each test has been completed.
6. When used as above, the tablets change the colour from green to red at a hardness of approximately 20ppm based on a sample volume of 10mls.

Other hardness test kits are available for more accurate testing eg.

Hardness Tablets

Directions: Take a 50ml sample of water in a screw capped bottle. Add one (1) tablet to sample, shake or crush to disintegrate. Repeat until last trace of reddish tinge disappears. The final colour is usually blue but with some water a greyish coloured end point is obtained.

Using 50ml sample -
Hardness ppm = (number of tablets x 40) - 20

LR (BW) Tablets

Directions: Take a 100ml sample of water in a screw capped bottle. Add one (1) tablet to sample, shake or crush to disintegrate. Repeat until last trace of reddish tinge disappears. The final colour is usually blue but with some water a greyish coloured end point is obtained.

Using 100ml sample -
Hardness ppm = (number tablets x 2) - 1

Contact IBC Water if further details are required.

LOCATION & INSTALLATION

1. The softener requires an inlet water pressure between 140kPa (20psi) and 690kPa (100psi).
2. The softener should service all water lines in the house except the toilet and outside taps. The softener should be positioned on a level flat surface close to a drain or any other properly trapped waste outlet.

The brass adaptors supplied are suitable for 20mm (3/4") female fittings and the softener should be connected to the supply with raw water to the inlet connector and softened water lines to the outlet as indicated on the valve.

3. When facing the front of the control the inlet is to the right and the outlet is to the left.
4. The system pressure must be between 140 kPa and 690 kPa psi.
5. If the system pressure is greater than 690kPa psi a **pressure reducing valve** must be installed.
6. The unit must be installed in accordance with local codes.
7. Do not over tighten connections.
8. Drain line ID must be at least 12mm.
9. Teflon tape should be used when installing the drain fitting into the control valve.
10. The drain line must be free of kinks.
11. A safety float with an air check is installed.
12. Insure all connections are tight.
13. To initiate regeneration, turn the twist the timer knob clockwise to the 2 hour position.

Note: DO NOT use teflon tape when connecting the fitting kits to the control valve.

14. There are two drain lines, one from the brine tank and one from the softener valve, these lines must have an air gap of at least 40mm or twice the pipe diameter at the drain entrance. The drain line from the brine tank is gravity fed and hence the drain is required to be below the outlet elbow on the tank.

The drain line from the softener valve is under pressure during regeneration but for correct operation a maximum of 2.4m of 15NB pipe with no rises can be connected.

A manual Bypass should be installed.

PLACING THE SOFTENER IN SERVICE

1. Turn the timer knob full clockwise from “off” to “off” ie. A time of 2 hours and open the inlet valve slightly. Slowly fill the resin tank. Air and water will be expelled out the drain line.
2. Open the inlet valve fully, the brine tank should fill to the proper preset level and then the float will close off.
3. Again turn the knob back clockwise to off (ie. 2-hours. position). Water should be drawn from the brine tank and pass out the drain. Allow to flow at the drain until any colour, objectionable taste and odours are absent and then return to anti-clockwise to off position.
4. The unit is now operational. Open the outlet valve and ensure the bypass valve is closed. Run the nearest cold water tap for a least 15 minutes to ensure the resin bed is flushed.

BRINE TANK

1. Place at least 25kg of a coarse refined grade of salt (Water Softener Salt) in the brine tank and **always maintain** dry salt above the water level.

The tank can hold up to 50kg of coarse salt.

2. Periodically it will be necessary to allow the salt to "run-out" and clean out the brine tank of accumulated silt and insoluble material.

REGENERATION

Always regenerate the unit before the softener is completely exhausted. Should complete exhaustion occur, two or possibly three regenerations, each spaced four (4) hours apart, will be needed to restore the resin. To regenerate the softener, turn the timer knob clockwise a full turn ie. off to off (do not exert undue pressure) and release. The unit will then automatically regenerate and return to service.

During regeneration raw (hard) water is bypassed to service so it is advisable to regenerate the unit when water is not needed.

541-030 VALVE

Water Conditioning Control System
Installation, Operating and Maintenance Manual

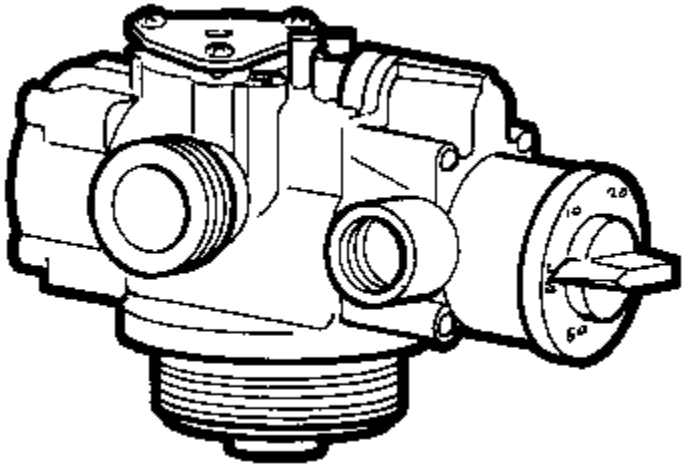
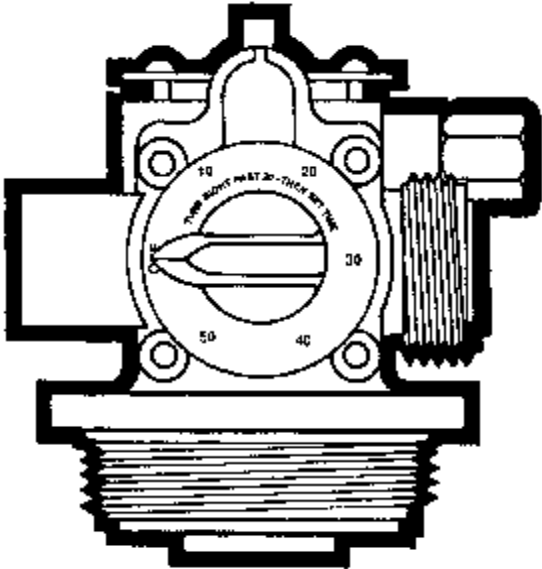

Cycle Flow Diagrams

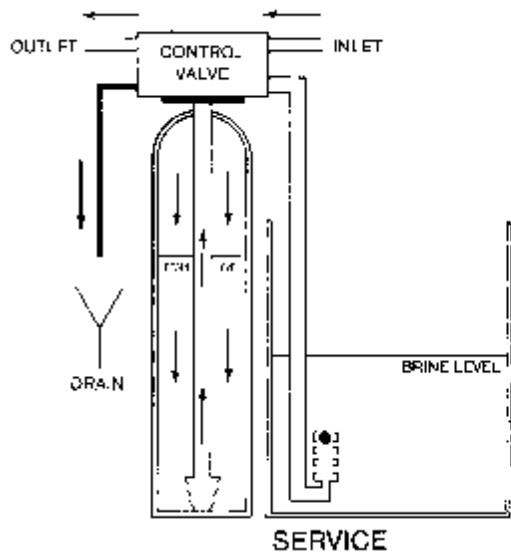

The service cycle position directs untreated water to flow down through the resin bed in the mineral tank and up through the riser tube. The water is conditioned when passing through the resin.

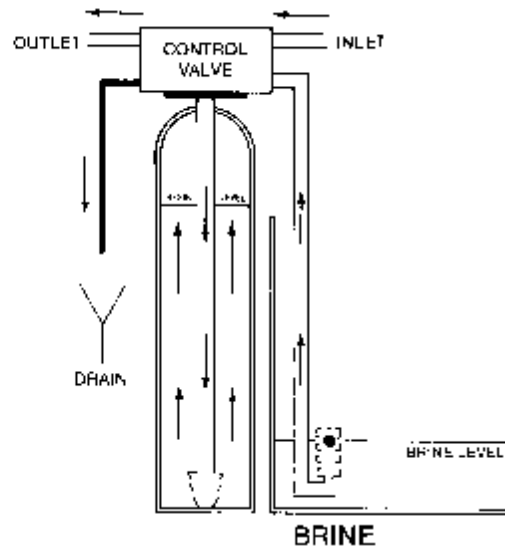

In brine draw, concentrated salt brine is drawn from the brine tank and directed to flow down through the riser tube and up through the resin bed to the drain. Brine is drawn until the air check in the brine tank closes.

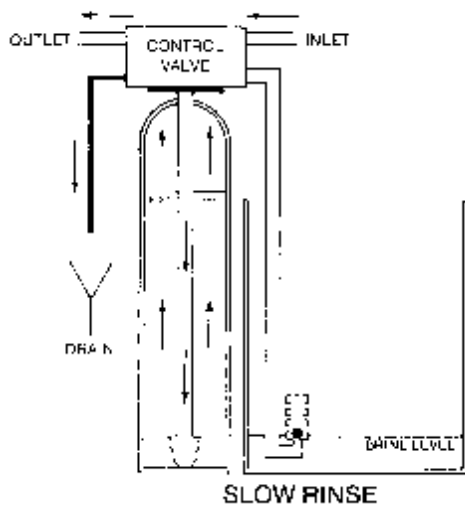

The slow rinse cycle position directs a slow flow of water down through the riser tube and up through the resin bed to drain. This slow flow of water pushes the brine solution through the resin bed.

NOTE: THIS CONTROL VALVE FUNCTIONS WITH A PRESSURISED BRINE LINE. THE USE OF A SAFETY FLOAT IN CONJUNCTION WITH THE AIR CHECK IS REQUIRED

Parts List

Item	P/N	Description	Qty
1.	15-88	Screw, Backcap	4
2.	541-207	Backcap, 3 Cycle	1
3.	541-206	Seal, Backcap	1
4.	541-239	Return Spring, Check Disc	1
5.	541-246	Check Disc	1
6.	541-325	Gasket, Injector	1
7.	428-	Injector (Specify Size)	1
8.	541-221	Cover Plate, Injector	1
9.	15-89	Screw, Injector Mount	3
10.	413-13	Filter Screen, Injector	1
11.	541-254	Spring Clip	1
12.	186-111-N	O-ring, Brine Fitting	1
13.	541-250-1	Brine Fitting	1
14.	19-19	C-Clip, Backwash Flow Adjuster	1
15.	541-243	Rinse Flow Adjuster w/o-rings	1
16.	529-244	Gasket, Cross Over Port	1
17.	541-244	Body Stem Assembly	1
18.	185-024-1	O-ring (Small), Seat Insert	1
19.	541-204	Seal Insert	1
20.	185-028-12	O-ring (Large), Seat Insert	1
21.	541-256	Main Diaphragm	1
22.	19-3	C-Clip, Main Diaphragm	1
23.	516-221	Return Spring, Main Diaphragm	1
24.	541-291-11	1 Hr. Timer Assembly	1
25.	15-87	Screw, Timer Mount	4
26.	19-90	Screw, Adapter Ring	2
27A.	185-231-1	O-ring, Structural Tank	1
27B.	186-105	O-ring, Park Tank	1
28.	541-232	Adapter Ring	1
29A.	185-211-1	O-ring, 13/16" Riser Adapter	1
29B.	185-214-1	O-ring, 1.050" Riser Adapter	1
30A.	541-205	13/16" Riser Adapter	1
30B.	541-218	1.050" Riser Adapter	1
31.	185-029-1	O-ring (Outside), Riser Adapter	1
32.	541-257-1	Valve Body & Seal	1

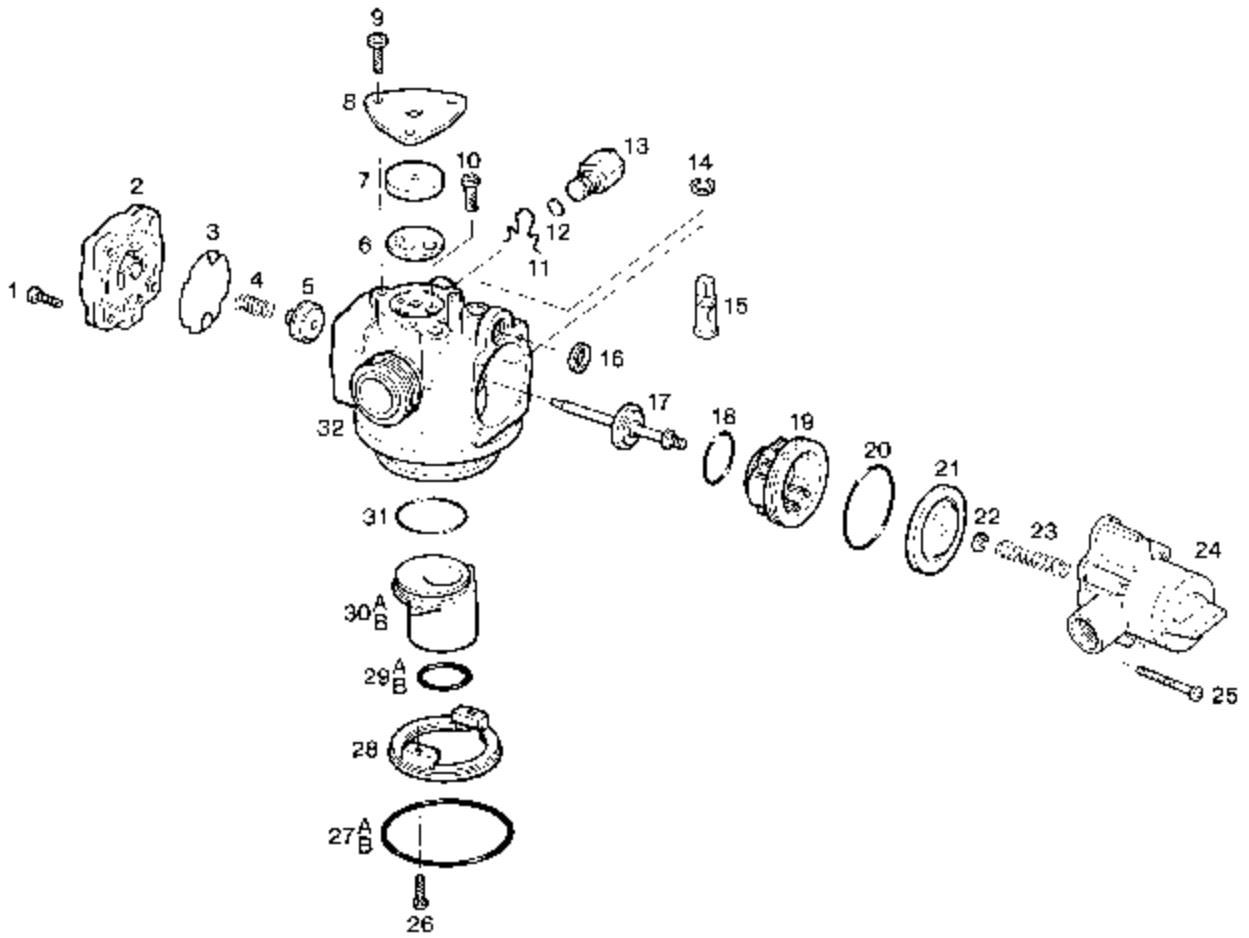

Troubleshooting Guide

Problem	Cause	Solution
1. Unit fails to regenerate.	<ul style="list-style-type: none"> a. Low inlet pressure. b. Drain line restricted. c. The brine injector is plugged. d. Main diaphragm is torn. e. Regeneration length too short 	<ul style="list-style-type: none"> a. Verify that the service inlet pressure is a minimum of 20 psi. b. Insure the drain line is free of kinks. c. Clean or replace injector. d. Replace diaphragm. e. Insure that the length of regeneration exceeds 20 minutes.
2. Hard water to service.	<ul style="list-style-type: none"> a. The bypass valve is open or faulty. b. No salt in storage tank. c. Not enough water in the storage tank. d. Unit fails to draw brine. e. Excessive water usage. f. Unit not regenerating. g. Loss of resin. h. Change in raw water hardness. i. Leak at the distributor tube. 	<ul style="list-style-type: none"> a. Close bypass valve. b. Add salt. c. Verify that the safety float is properly set. d. See symptom/cause # 6. e. Check regeneration frequency. f. See symptom/cause # 1. g. See symptom/cause # 4. h. Test water hardness. i. Verify that the distributor tube is seated correctly and is not cracked.
3. Excessive salt usage.	<ul style="list-style-type: none"> a. Excessive water in storage tank. b. Regeneration is taking place too frequently. c. Faulty safety float. 	<ul style="list-style-type: none"> a. Verify that the safety float is properly set. b. Verify water usage matches system size and salt dosage. c. Replace safety float.
4. Loss of resin.	<ul style="list-style-type: none"> a. Faulty air check in storage tank. b. Leak at the distributor tube. 	<ul style="list-style-type: none"> a. Clean or replace air check. b. Verify that the distributor tube is seated correctly and is not cracked.
5. Salt water to service.	<ul style="list-style-type: none"> a. Brine/slow rinse cycle time set too short. b. Excessive water in the storage tank. c. Brine injector undersized. 	<ul style="list-style-type: none"> a. Verify cycle time. b. Verify that the safety float is adjusted correctly and properly. c. Verify proper injector selection.
6. Control fails to draw brine.	<ul style="list-style-type: none"> a. Brine injector plugged. b. Filter screen plugged c. Loose line is restricted. d. Drain line is restricted e. Low inlet pressure. f. Main diaphragm is torn. 	<ul style="list-style-type: none"> a. Clean and replace injector. Follow the procedure detailed in the parts replacement section of this manual. b. Clean and replace screen. c. Verify that all the brine line connections are tight. d. Insure that the drain line is not kinked or plugged. e. Verify that the service inlet pressure is a minimum of 20 psi. f. Replace diaphragm.
7. Continuous flow to drain.	<ul style="list-style-type: none"> a. Defective clock assembly 	<ul style="list-style-type: none"> a. Replace clock assembly.
8. Loss of water pressure.	<ul style="list-style-type: none"> a. Iron build up in mineral tank. b. Lower distributor basket crushed. 	<ul style="list-style-type: none"> a. Increase salt dosage or regenerate more frequently. b. Replace basket and verify that the distributor is cut 1/2 inch below the top of the tank threads.

Parts Replacement

General Information

Familiarise yourself with the parts replacement procedures and component parts thoroughly before attempting any repair.

Insure that the unit is in the bypass position and relieve the system pressure before attempting any repair procedure.

Required Tools

The following tools are required to perform routine maintenance on this valve:

- Phillips Screwdriver
- Needle Nose Pliers
- Adjustable Wrench
- Small Standard Screwdriver

Timer Assembly Replacement

1. Place the bypass valve into "bypass" position.
2. Relieve the system pressure.
3. Remove the four (4) head mounting screws.
4. Lift the timer assembly away from the valve body.
5. Follow these steps in reverse to reinstall the timer assembly.

Note: Prior to re-installment insure that the main return spring is centred over the main diaphragm.

Main Diaphragm Replacement

1. Place the bypass valve into the "bypass" position.
2. Relieve the system pressure. Remove the four (4) head mounting screws.
3. Lift the timer assembly away from the valve body.
4. Remove the c-clip from the centre of the diaphragm.
5. Lift the diaphragm away from the body stem assembly.
6. Follow these steps in reverse to reinstall the timer assembly.

Note: Prior to re-installment insure that the main return spring is centred over the main diaphragm and that the outside edges of the main diaphragm are tucked into the valve body.

Rinse Adjustment Valve Replacement

1. Place the bypass valve into "bypass" position.
2. Relieve the system pressure. Remove the four (4) head mounting screws.
3. Lift the timer assembly away from the valve body.
4. Remove the c-clip from the centre of the diaphragm.
5. Lift the diaphragm away from the body stem assembly.
6. Remove the seat assembly.
7. Disconnect the large c-clip located on top of the rinse adjustment valve.
8. Press the rinse adjustment valve down and out through the valve body assembly.
9. Inspect the o-rings on the valve for wear. Clean or replace the valve assembly if necessary.
10. Lightly lubricate the o-rings with a Dow 111 Silicone based lubricant.
11. Follow these steps in reverse to re-install the rinse adjustment valve.

Drain Seat Replacement

1. Place the bypass valve into the "bypass" position.
2. Relieve the system pressure.
3. Disconnect the drain fitting from the control valve drain outlet.
4. Use a large standard screwdriver to remove the drain seat. Turn out counterclockwise.
5. Prior to installing the drain seat, lubricate the o-ring(s) with dish soap.
6. Turn in the drain seat, until the fitting becomes bottoms out.
7. To properly align the drain seat with the drain paddle back out seat four (4) full turns.
8. Pressurise the system and check drain for leaks.

Note: After backing out the drain seat the seat may still require minor adjustment to eliminate leaks. Turn the seat in or out until the leak to drain stops.

Injector and Filter Screen Replacement

1. Place the bypass valve into the "bypass" position.
2. Relieve the system pressure.
3. Remove the three (3) screws from the triangular cover plate.
4. Lift away the cover plate.
5. Remove the injector from the valve body and separate the gasket from the injector.
6. Inspect the injector cavities for blockage.
7. Remove the filter screen from the valve body and inspect the screen for dirt. Replace if necessary.
8. Follow the steps in reverse to re-install the injector and filter screen.

Note: Prior to re-installing the injector gasket, insure that the side marked "OUT" is facing the injector.

Riser Replacement

1. Place the bypass valve into the "bypass" position.
2. Relieve the system pressure.
3. Disconnect the unit from the bypass connections.
4. Remove the unit from the resin tank.
5. Turn out the upper distributor basket from the unit adapter ring.
6. Remove the two (2) adapter hold down screws, and lift away the adapter ring.
7. Separate riser assembly from valve body.
8. Clean the riser o-rings and wipe out the valve body cavity.
9. Use the Dow 111 Silicone based lubricant to lightly lubricate the riser o-rings and the valve body cavity.
10. Follow these steps in reverse to re-install the riser assembly.

Check Disc Replacement

1. Place the bypass valve into the "bypass" position.
2. Relieve system pressure.
3. Remove the four (4) screws from the backcap.
4. Place a hand under the backcap and remove the backcap. The check disc return spring will fall into your hand.
5. Remove the check disc from the back of the body stem assembly.
6. Inspect the rubber seal on the check disc for wear. Clean or replace if necessary.
7. Re-install the check disc on body stem assembly.
8. Place a small amount of Dow 111 silicone based lubricant on the back cap centre post.

9. Insure that the back cap gasket is properly seated in Backcap.
10. Install check disc return spring into centre post.
11. Align the mark on top of the back cap with the mark on the valve body and carefully direct open end of return spring into centre post of the check disc.

12. Install the four (4) back cap screws.
13. Pressurise system and check for leaks.

Body Stem Assembly Replacement

1. Place the bypass valve into the "bypass" position.
2. Relieve the system pressure.
3. Remove the four (4) head mounting screws.
4. Lift the timer assembly away from the valve body.
5. Remove the c-clip from the centre of the diaphragm.
6. Lift the diaphragm away from the body stem assembly.
7. Remove the seat assembly.
8. Lift out the body stem assembly.
9. Inspect the centre check disc rubber seal for wear. Clean or replace if necessary.
10. Re-install the body stem assembly.
11. Lightly lubricate the seat assembly o-rings with a Dow 111 Silicone based lubricant.
12. Re-install the seat assembly, insure that one of the two (2) flats is facing towards the top of the valve body.
13. Re-install the main diaphragm and the timer assembly.
14. It is now necessary to reseal the rear check disc. Refer to the Check Disc Replacement procedure.

BRINE VALVE ASSEMBLY

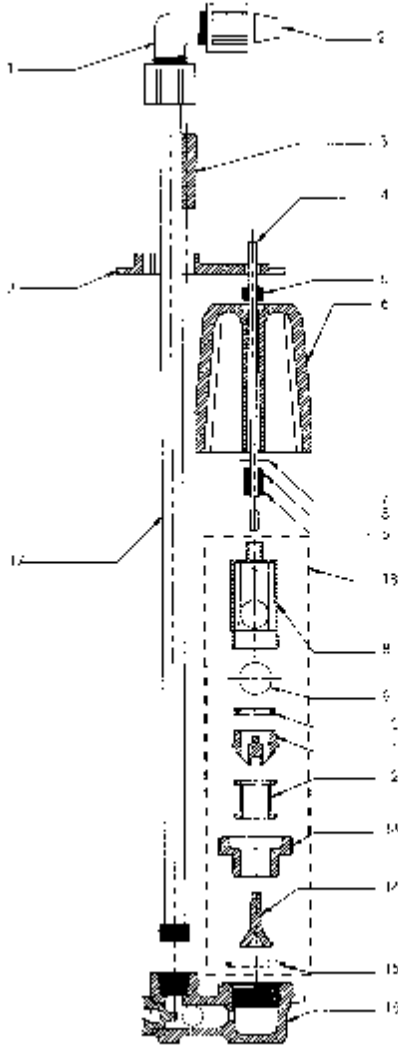

Detailed Assembly Information

Drawing Number	Order Number	Description
1	S1366	3/8" x 3/8" union elbow (must be purchased separately)
2	S1197	3/8" polytube insert (must be purchased separately)
3 or 3	H7041	1/4" guide and lock (sold as a set)
3	H7041-3/8	3/8" guide and lock (sold as a set)
4 or 4	H7038	float rod - 14"
4	H7038-01	float rod - 24"
5	H7039	float grommet (2 required for Standard, 3 required for Control and High Flow)
6 or 6	H7040	light bell float (for Standard)
6	H7040-02	heavy bell float (for Control and High Flow)
7	H7042	washer (for Standard only)
8	H7046	ball cage
9	H7047	air check ball
10	H7048	quad cup seat
11	H7046-C	ball cage cone
12	H7052	spool seat
13	H7044	crown nut
14	H7051	stern
15	H7035	quad ring
16 or 16	H7030	464 Standard body with ball (black)
16 or 16	H7030-01	464 High Flow body, no ball (white)
16	H7030-02	464 Control flow body, with ball (blue)
17 or 17	H1035-26.75*	3/8" x 26.75" rigid PVC (for 28" brine wells)
17 or 17	H1035-27.75*	3/8" x 27.75" rigid PVC (for 29" brine wells)
17 or 17	H1035-28.75*	3/8" x 28.75" rigid PVC (for 30" brine wells)
17	H1035-34.75*	3/8" x 34.75" rigid PVC (for 36" brine wells)
18	H7028	air check assembly

*Riser pipe includes 1/4" male threaded fitting on one end.

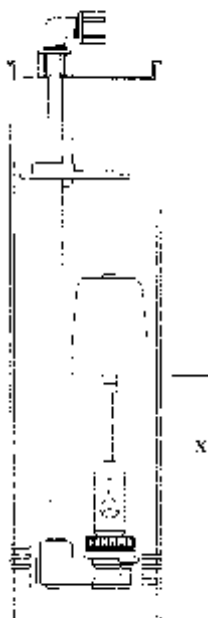

Windsor Cabinet

Model	Float Distance (X)
SAS0715	100mm
SAS0922	200mm
SAS1029	260mm

Adjustment of Softener Brine Valve

1. Lift float rod to full up position.
2. Set float to distance shown. Measure from the top of the crown nut to the bottom of the float.